

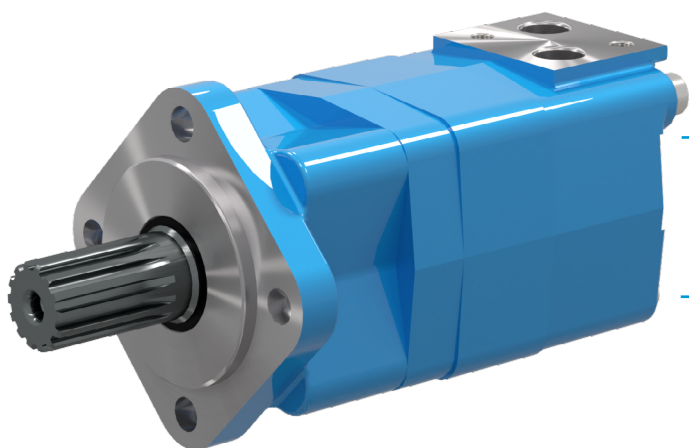

BREVINI[®]

Motion Systems



HR Orbital Motors



Motor Features	F2
Motor Technical Specifications	F3
Performance Curves	F4
Pressure Data	F8
Max. Permissible Shaft Seal Pressure	F8
Pressure Loss	F8
Other Informations	F9
Ordering Code	F10
Dimensions and Weight	F14
Brake feature F/L version	F18
Dimensions and Weight	F20
Shaft End	F24
Main Ports	F26
Special version	F28
Options	F29

Click **i** button to return to main index

Click **DANA** button to return to section index



HR

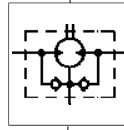

S
Standard Version

W
Wheel Version

C
Bearingless
Version

F
Brake Version

L
Wheel Version
with brake

M
Short Version
for Gear Box

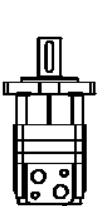

A4

A2

C4

B4

A4

C4

M4

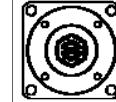
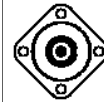
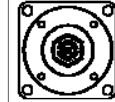

Shaft supported by two heavy duty tapered roller bearings that ensure outstanding radial load capacity Max 40000 N [Max. 9000 lbf].

Disc valve distribution with automatic compensation of backlash done by fluid under pressure: lower drain figures are then guaranteed together with high efficiency. The motor is supplied with internally built-in check valves.

HR

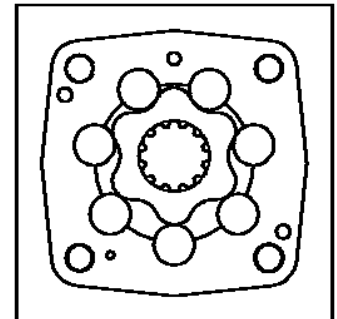
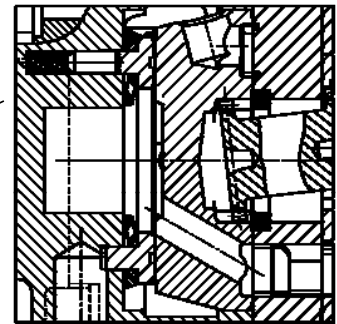
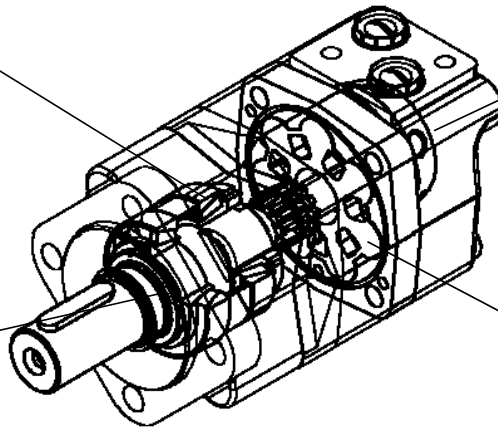
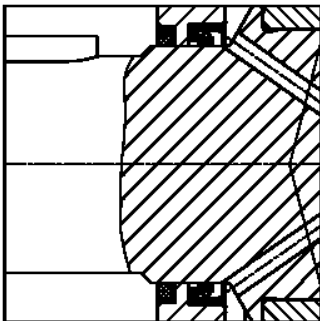
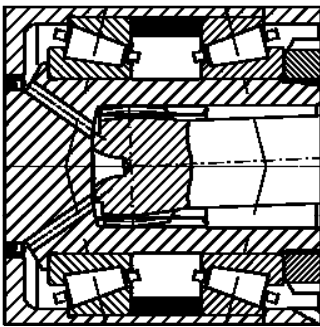

Dust Seal for high pressure of the output shaft. The motor can work with casing pressure up to 160 bar [2320 psi].

Heavy duty, roller type stator meant to work at high pressure and to guarantee extra long lasting.

Click **DANA** button to return to section index

Click **i** button to return to main index



Motor	Displacement cm ³ /rev [in ³ /rev]	Max. input pressure bar [psi]		Max. differential pressure bar [psi]		Max. torque Nm [lbf-ft]		Max. flow l/min [U.S. gpm]		Max. speed rpm		Max. power kW [hp]	
		Cont Int ¹⁾ Peak ²⁾	210 [3045] 310 [4495] 310 [4495]	Cont Int ¹⁾ Peak ²⁾	205 [2972] 310 [4495] 310 [4495]	Cont Int ¹⁾	235 [173] 345 [254]	Cont Int ¹⁾	75 [19.8] 80 [21.1]	Cont Int ¹⁾	932 995	Cont Int ¹⁾	23 [30.8] 36 [48.2]
HR 080	80.4 [4.9]	Cont Int ¹⁾ Peak ²⁾	210 [3045] 310 [4495] 310 [4495]	Cont Int ¹⁾ Peak ²⁾	205 [2972] 310 [4495] 310 [4495]	Cont Int ¹⁾	235 [173] 345 [254]	Cont Int ¹⁾	75 [19.8] 80 [21.1]	Cont Int ¹⁾	932 995	Cont Int ¹⁾	23 [30.8] 36 [48.2]
HR 100	100 [6.1]	Cont Int ¹⁾ Peak ²⁾	210 [3045] 310 [4495] 310 [4495]	Cont Int ¹⁾ Peak ²⁾	205 [2972] 310 [4495] 310 [4495]	Cont Int ¹⁾	295 [217] 445 [328]	Cont Int ¹⁾	75 [19.8] 95 [25]	Cont Int ¹⁾	750 950	Cont Int ¹⁾	23.1 [30.9] 44.2 [59.2]
HR 130	125.7 [7.66]	Cont Int ¹⁾ Peak ²⁾	210 [3045] 310 [4495] 310 [4495]	Cont Int ¹⁾ Peak ²⁾	205 [2972] 310 [4495] 310 [4495]	Cont Int ¹⁾	375 [276] 545 [401]	Cont Int ¹⁾	75 [19.8] 95 [25]	Cont Int ¹⁾	596 755	Cont Int ¹⁾	23.4 [31.3] 43.1 [57.7]
HR 160	160 [9.76]	Cont Int ¹⁾ Peak ²⁾	210 [3045] 310 [4495] 310 [4495]	Cont Int ¹⁾ Peak ²⁾	205 [2972] 260 [3770] 310 [4495]	Cont Int ¹⁾	465 [342] 570 [420]	Cont Int ¹⁾	75 [19.8] 95 [25]	Cont Int ¹⁾	468 593	Cont Int ¹⁾	18.2 [24.3] 22.5 [30.1]
HR 200	200 [12.2]	Cont Int ¹⁾ Peak ²⁾	210 [3045] 310 [4495] 310 [4495]	Cont Int ¹⁾ Peak ²⁾	205 [2972] 260 [3770] 310 [4495]	Cont Int ¹⁾	580 [427] 670 [494]	Cont Int ¹⁾	75 [19.8] 95 [25]	Cont Int ¹⁾	375 475	Cont Int ¹⁾	15.2 [20.3] 22.5 [30.1]
HR 250	250 [15.25]	Cont Int ¹⁾ Peak ²⁾	210 [3045] 310 [4495] 310 [4495]	Cont Int ¹⁾ Peak ²⁾	205 [2972] 260 [3770] 310 [4495]	Cont Int ¹⁾	710 [523] 820 [604]	Cont Int ¹⁾	75 [19.8] 95 [25]	Cont Int ¹⁾	300 380	Cont Int ¹⁾	14.2 [19] 19.5 [26.1]
HR 315	314.5 [19.18]	Cont Int ¹⁾ Peak ²⁾	210 [3045] 310 [4495] 310 [4495]	Cont Int ¹⁾ Peak ²⁾	205 [2972] 240 [3480] 310 [4495]	Cont Int ¹⁾	885 [652] 960 [707]	Cont Int ¹⁾	75 [19.8] 95 [25]	Cont Int ¹⁾	238 302	Cont Int ¹⁾	11 [14.7] 19.5 [26.1]
HR 400	393 [23.97]	Cont Int ¹⁾ Peak ²⁾	210 [3045] 310 [4495] 310 [4495]	Cont Int ¹⁾ Peak ²⁾	155 [2247] 190 [2755] 225 [3250]	Cont Int ¹⁾	860 [633] 980 [722]	Cont Int ¹⁾	75 [19.8] 95 [25]	Cont Int ¹⁾	190 241	Cont Int ¹⁾	11 [14.7] 13 [17.4]

		HR 080	HR 100	HR 130	HR 160	HR 200	HR 250	HR 315	HR 400
Max starting pressure with no load	bar [psi]	11 [159]	10 [145]	10 [145]	8 [116]	8 [116]	8 [116]	8 [116]	8 [116]
Min. starting torque (At. Max Δp)	Nm [lbf-ft]	Cont. 180 [133] Int. 270 [199]	Cont. 230 [169] Int. 340 [250]	Cont. 300 [221] Int. 420 [309]	Cont. 370 [272] Int. 440 [324]	Cont. 465 [343] Int. 522 [385]	Cont. 568 [419] Int. 640 [472]	Cont. 700 [516] Int. 760 [560]	Cont. 680 [501] Int. 775 [571]

¹⁾ Intermittent duty must not exceed 10% each minute.

²⁾ Peak duty must not exceed 1% each minute.

* For motors with the shafts in the table below the Max. admissible torque is reduced as follows:

* Max. admissible torque for shaft type	Nm [lbf-ft]	CL254 CYLINDRICAL SHAFT		SE250 SPLINED SHAFT	
		Cont	300 [221]	Cont	360 [265]
		Int ¹⁾	410 [302]	Int ¹⁾	450 [332]

¹⁾ Intermittent duty must not exceed 10% each minute.



HR 080

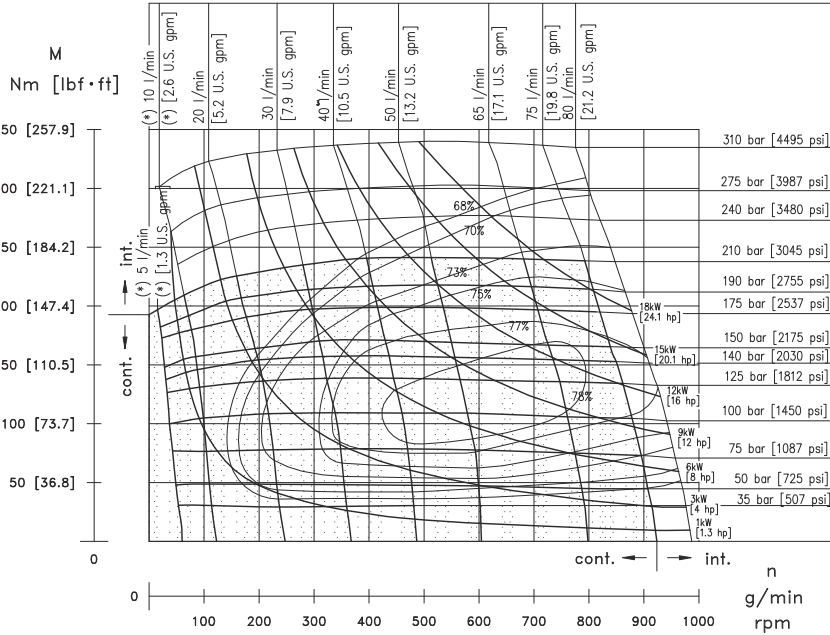

Exceeding continuous pressure values or exceeding flow values indicated, must not occur simultaneously.

(*) Performances data are referred to standard motors.

For obtain higher performances, when the motor is used with flow < 10 l/min [< 2.64 U.S. gpm], we suggest to use LW (Low Leakage) version.

HR 100

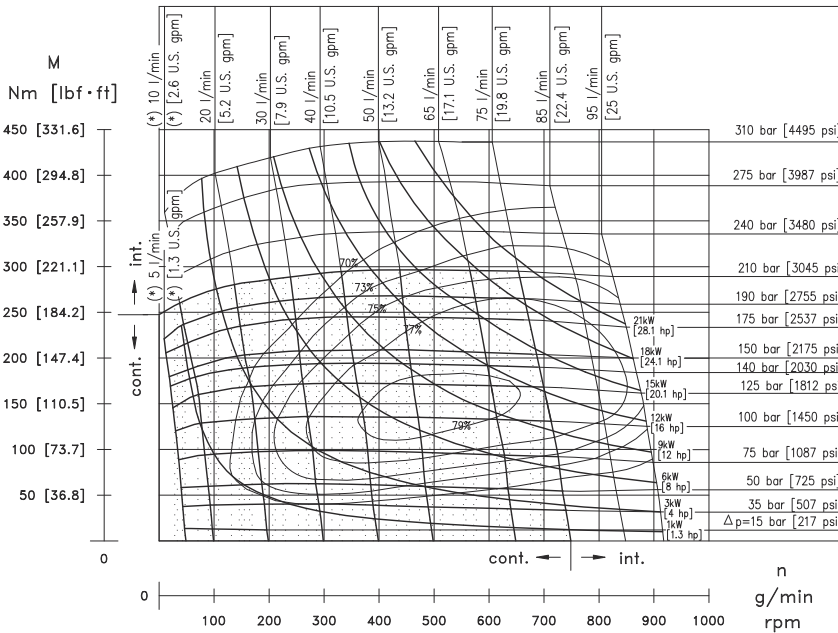

Exceeding continuous pressure values or exceeding flow values indicated, must not occur simultaneously.

(*) Performances data are referred to standard motors.

For obtain higher performances, when the motor is used with flow < 10 l/min [< 2.64 U.S. gpm], we suggest to use LW (Low Leakage) version.

HR 130

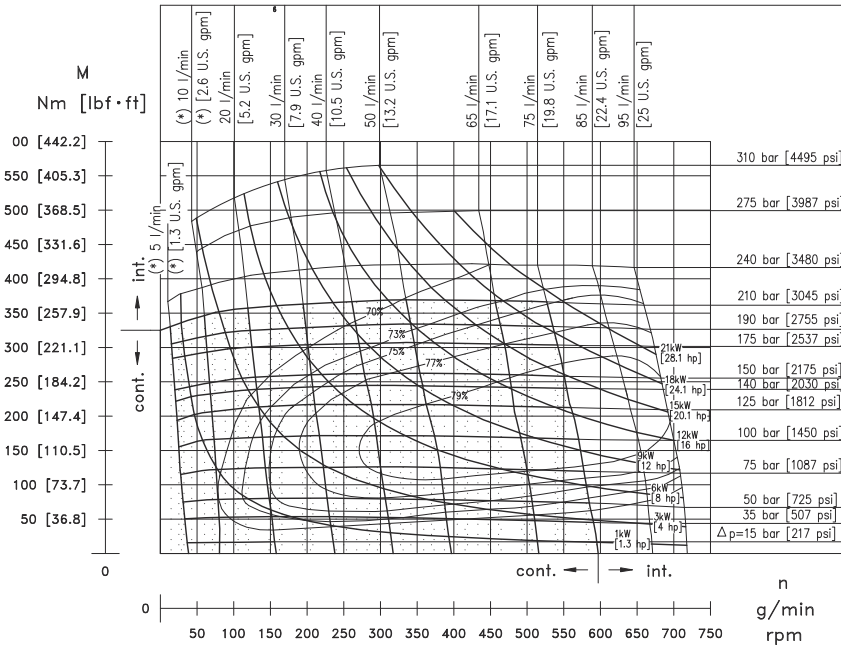

Exceeding continuous pressure values or exceeding flow values indicated, must not occur simultaneously.

(*) Performances data are referred to standard motors.

For obtain higher performances, when the motor is used with flow < 10 l/min [< 2.64 U.S. gpm], we suggest to use LW (Low Leakage) version.

HR 160

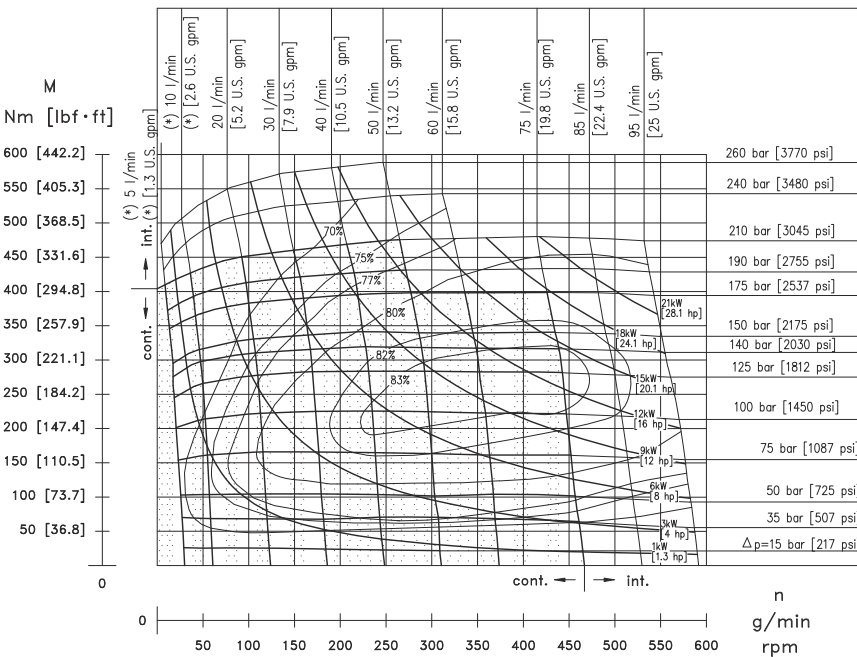

Exceeding continuous pressure values or exceeding flow values indicated, must not occur simultaneously.

(*) Performances data are referred to standard motors.

For obtain higher performances, when the motor is used with flow < 10 l/min [< 2.64 U.S. gpm], we suggest to use LW (Low Leakage) version.



HR 200

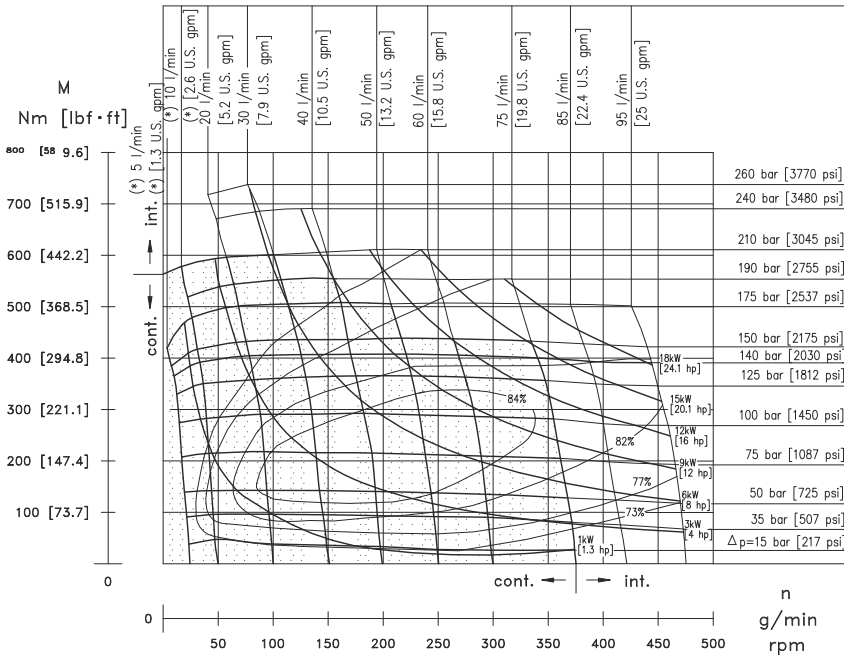

Exceeding continuous pressure values or exceeding flow values indicated, must not occur simultaneously.

(*) Performances data are referred to standard motors.

For obtain higher performances, when the motor is used with flow < 10 l/min [< 2.64 U.S. gpm], we suggest to use LW (Low Leakage) version.

HR 250

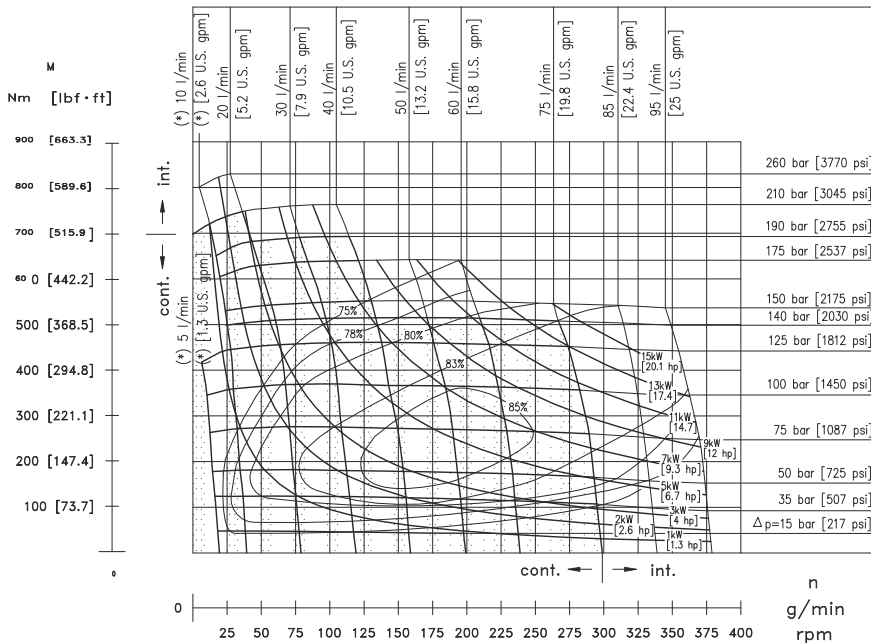

Exceeding continuous pressure values or exceeding flow values indicated, must not occur simultaneously.

(*) Performances data are referred to standard motors.

For obtain higher performances, when the motor is used with flow < 10 l/min [< 2.64 U.S. gpm], we suggest to use LW (Low Leakage) version.

HR 315

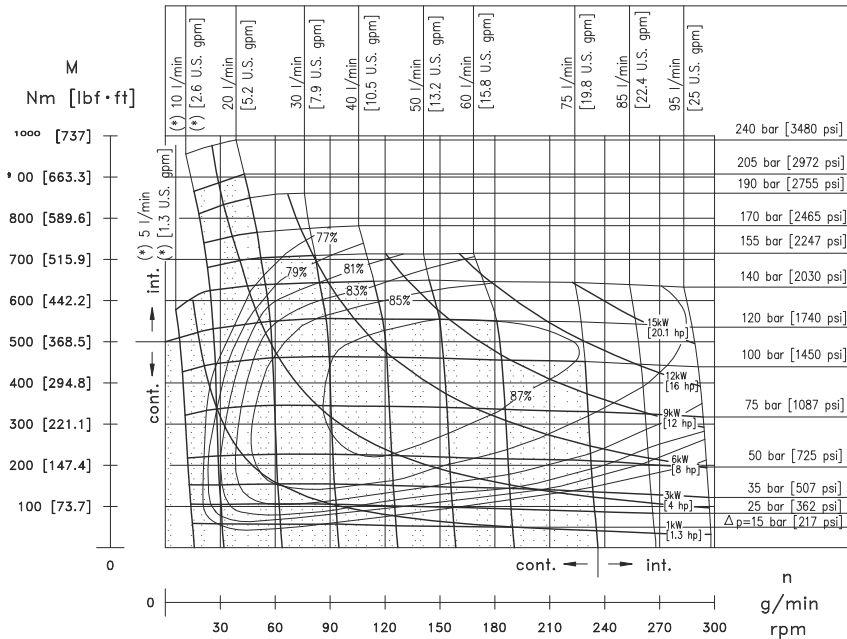

Exceeding continuous pressure values or exceeding flow values indicated, must not occur simultaneously.

(*) Performances data are referred to standard motors.

For obtain higher performances, when the motor is used with flow < 10 l/min [< 2.64 U.S. gpm], we suggest to use LW (Low Leakage) version.

HR 400

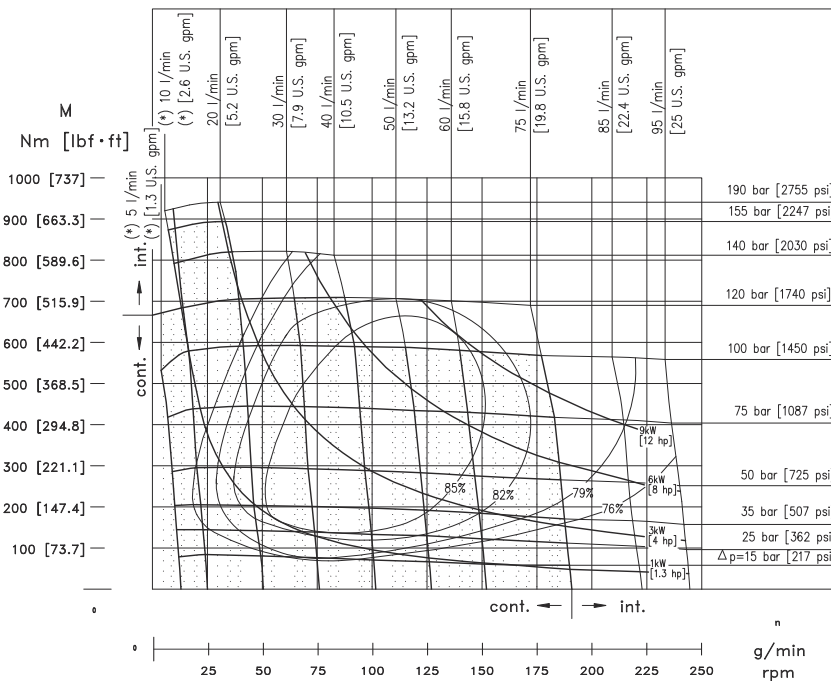

Exceeding continuous pressure values or exceeding flow values indicated, must not occur simultaneously.

(*) Performances data are referred to standard motors.

For obtain higher performances, when the motor is used with flow < 10 l/min [< 2.64 U.S. gpm], we suggest to use LW (Low Leakage) version.

Click **i** button to return to main index

Click **DANA** button to return to section index



Max. Permissible Shaft Seal Pressure

Max. return pressure without drain line or max. pressure in the drain line.
For pressure and speeds not showed in the curve below, please contact Dana Brevini.

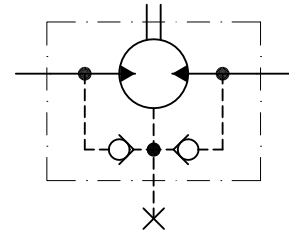
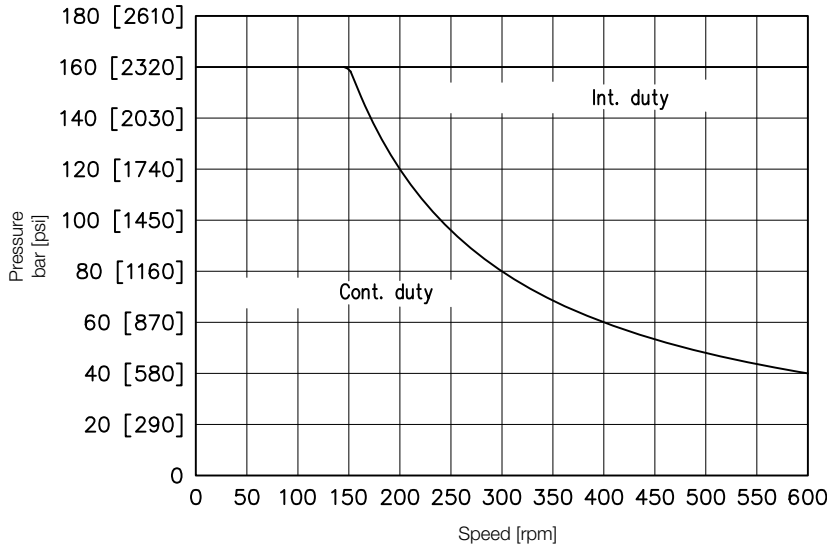

Pressure Loss

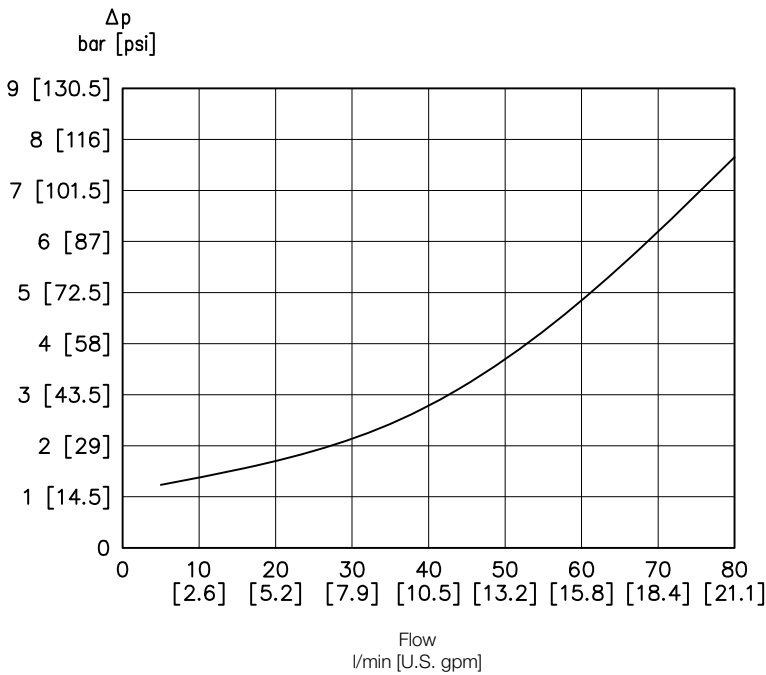
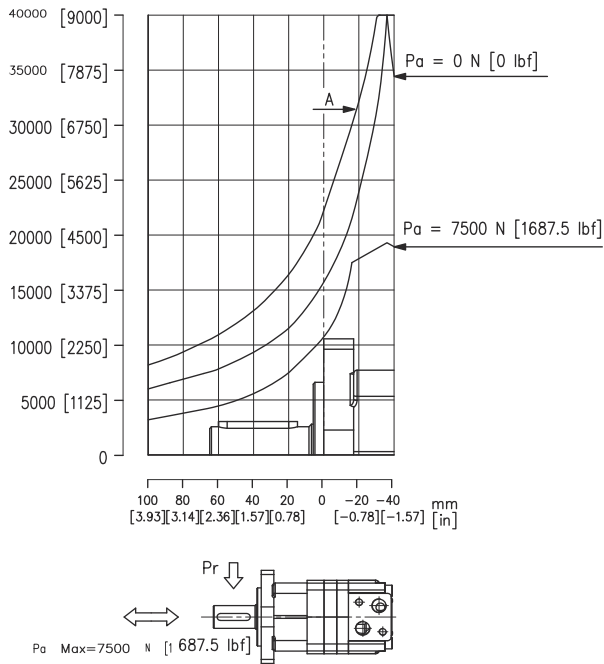

Diagram according to tests done with a relevant number of motors and using hydraulic oil with cinematic viscosity of 37 cSt at 45 C° temperature.

Shaft Load

S Version - F Version



W Version - L Version

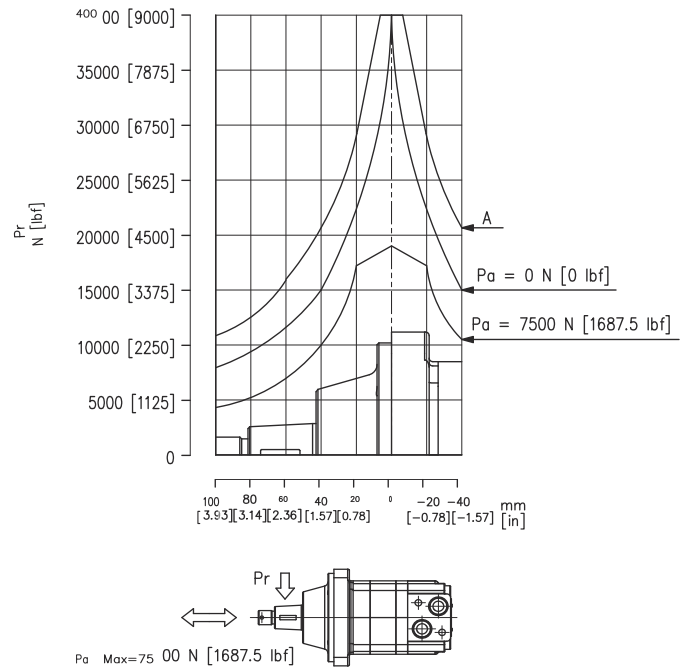

Loads diagram is for a bearings life L_{10h} of 1600 hours at 200 rpm when mineral base hydraulic oil with a sufficient content of anti-wear additives is used. Bearing life calculation refers to a 90% degree of reliability.

Curve "A" shows the maximum radial load that can be taken by the bearings under maximum static load duty.

The following alphanumeric digits system has been developed to identify all of the configuration options for the HR motors. Use the model code below to specify the desired features. All alphanumeric digits system of the code must be present when ordering. We recommend to carefully read the catalogue before filling the ordering code.

1	2	3	4	5	6	7	8	9	10	11	12	13
Series	Displacement	Version	Mount flange	Shaft end	Main port	Seal	Valve	Valve feature	Flushing valve	Option	Version feature	Painting
HR	200	S	A4	CL025	M09	N	M091	032	06	TZ	OKK	01

1	Series	
HR	Orbital motor	

2	Displacement	
080	80 cm ³ /giro [4.88 in ³ /rev]	
100	100 cm ³ /giro [6.1 in ³ /rev]	
130	130 cm ³ /giro [7.93 in ³ /rev]	
160	160 cm ³ /giro [9.76 in ³ /rev]	
200	200 cm ³ /giro [12.2 in ³ /rev]	
250	250 cm ³ /giro [15.25 in ³ /rev]	
315	315 cm ³ /giro [19.21 in ³ /rev]	
400	400 cm ³ /giro [24.4 in ³ /rev]	

3	Version	
S	Standard Version	
W	Wheel Version	
C	Bearingless Version	
M	Short Bearingless Version for Gear Box	
F	Brake Version	
L	Wheel Version with brake	

4	Mounting Flange	Version					
		S	W	C	M	F	L
M4	Short flange for Gear Box	-	-	-	●	-	-
A4	4 Bolt Ø 82.5 mm [Ø 3.2 in]	●	-	-	-	●	-
A2	SAE A 2 Bolt	●	-	-	-	1)	-
B4	ISO 4 Bolt Ø 100 mm [Ø 3.9 in]	-	-	●	-	-	-
CM	ISO 4 Bolt Ø 125 mm [Ø 4.9 in]	-	●	-	-	-	●

1) On request

- Available
- Not Available

Click **DANA** button to return to section index

Click **i** button to return to main index

5

Shaft end		Version					
		S	W	C	M	F	L
DB001	Dog Bone T=12 12/24 DP	-	-	●	●	-	-
CL025	Parallel keyed Ø25 mm [0.97 in]	●	-	-	-	-	-
CL254	Parallel keyed Ø25.4 mm [1 in]	●	-	-	-	-	-
C3175	Parallel keyed Ø31.75 mm [1.23 in]	●	-	-	-	-	-
CL320	Parallel keyed Ø32 mm [1.24]	●	●	-	-	●	●
CN320	Tapered Shaft	●	●	-	-	●	●
SE250	Splined Shaft (SAE 6B 1" spline)	●	-	-	-	-	-
SC320	Splined Shaft (ASA 12/24 spline) - Europe Version	●	●	-	-	-	-
SE320	Splined Shaft (ASA 12/24 spline) - USA Version	●	-	-	-	-	-
SE350	Splined Shaft (P.t.o. DIN 9611 Form1)	●	-	-	-	-	-

6

Main Port		Version					
		S	W	C	M	F	L
M09	1/2 G BSPP (32x22) Main Ports (standard)	●	●	●	●	●	●
S09	7/8" - 14 UNF (32x22) Main Ports	●	●	●	-	●	●
L09	1" 1/16 - 12 UN (Main Ports Positioned 180° apart)	●	●	●	-	●	●
F09	1" 1/16 - 12 UN (End Main Ports)	●	●	●	-	●	●

7

Seal	
N	NBR (standard)
V	FKM

8

Valve		Main Port			
		M09	S09	L09	F09
xxxx	Not required	●	●	●	●
M091	Pressure relief valve VAF 09 - D	●	-	-	-
M092	Anticavitation and Anti-Shock Valve VAAF 09 / 40	●	-	-	-
M093	Overcentre Valve with VCD1 09 - S/AF	●	-	-	-
M094	Double-acting overcentre valve with shuttle valve VCR1 09 - D/AF	●	-	-	-
M095	Double-acting overcentre valve with shuttle valve VCR1 09 D/AF LDP	●	-	-	-
M096	Flow Control Valve VRP 09	●	-	-	-
M097	Pressure relief valve VAF 09 - D/AF	●	-	-	-



● Available
- Not Available

Click **i** button to return to main index

Click **DANA** button to return to section index



9		Valve	Valve						
			xxxx	M091	M092	M093	M094	M095	M096
000	Feature not necessary	●	-	-	-	-	-	-	-
032	Not Set (50÷100 bar [725 to 1450 psi])	-	●	-	-	-	-	-	-
018	Not Set (50÷210 bar [725 to 3045 psi])	-	-	●	-	-	-	-	-
029	Not Set (30÷220 bar [435 to 3190 psi])	-	-	-	-	●	●	-	-
019	Not Set (Max pressure 315 bar [4567 psi])	-	-	-	-	-	-	●	-
020	Not Set (100÷200 bar [1450 to 2900 psi])	-	●	-	-	-	-	-	-
022	Not Set (100÷280 bar [1450 to 4060 psi])	-	-	-	-	-	-	-	●
700	Pilot Ratio 7:1	-	-	-	●	-	-	-	-
300	Pilot Ratio 7:1	-	-	-	●	-	-	-	-

10		Flushing Valve (*)	Main Port			
			M09	S09	L09	F09
xx	Not required	●	●	●	●	
06	VSC/F Flushing valve - 6 l/min [1.58 U.S. gpm]	●	●	-	-	
09	VSC/F Flushing valve - 10.5 l/min [2.77 U.S. gpm]	●	●	-	-	
15	VSC/F Flushing valve - 15 l/min [3.96 U.S. gpm]	●	●	-	-	

11		Option	Version					
			S	W	C	M	F	L
xx	None	●	●	●	●	●	●	
03	Reverse rotation	●	●	●	●	●	●	
TZ	Tachometer + sensor 2-channel-Hall effect (30 pulse)	●	-	-	-	-	-	
ZT	Tachometer + sensor 2-channel-Hall effect (55 pulse)	●	-	-	-	-	-	
ZJ	Tachometer + 9046087 sensor Hall effect (55 pulse)	●	-	-	-	-	-	

12		Shaft end	Version					
			S	W	C	M	F	L
xxx	Standard version	●	●	-	-	●	●	
OKK	Double drain port 1/4 G (BSPP) (at delivery side)	●	●	-	-	-	-	
SKK	Double drain port 7/16" - 20UNF (at delivery side)	●	●	-	-	-	-	
LWK	Low leakage	●	●	●	●	●	●	
SWK	Double drain port 7/16" - 20UNF (at delivery side) + Low leakage	●	●	● ¹⁾	-	-	-	
KWK	Double drain port 1/4 G (BSPP) (at delivery side) + Low leakage	●	●	● ¹⁾	-	-	-	
03K	Brevini SDU31 gear box Version + Low leakage	-	-	-	●	-	-	
04K	12 Springs / 10 Contacts Version (available with displacement 100-315)	-	-	-	-	●	●	
05K	8 Springs Version (available with displacement 250 - 315 - 400)	-	-	-	-	●	●	
06K	Increased braking torque Version (available with displacement 200-250)	-	-	-	-	●	●	
08K	Low leakage + 8 Springs Version (available with displacement 250 - 315 - 400)	-	-	-	-	●	●	
09K	Increased braking torque Version (available with displacement 200-250) + Low leakage	-	-	-	-	●	●	
10K	Brake housing SAE ports	-	-	-	-	-	-	

*) It is possible to combine the flushing valves only with VAF 09 - D valve.

1) Assembly, please contact Dana Brevini for further information.

● Available
- Not Available

Click **DANA** button to return to section index

Click **i** button to return to main index



13

Painting

xx	Not Painted
01	Black Painted RAL 9005
02	Blue Painted RAL 5015
05	Gray Painted RAL 7016



Dimensions and Weight

- 1
- 2
- 3
- 4
- 5
- 6
- 7
- 8
- 9
- 10
- 11
- 12
- 13

HR S A2/A4 M09/S09/L09/F09

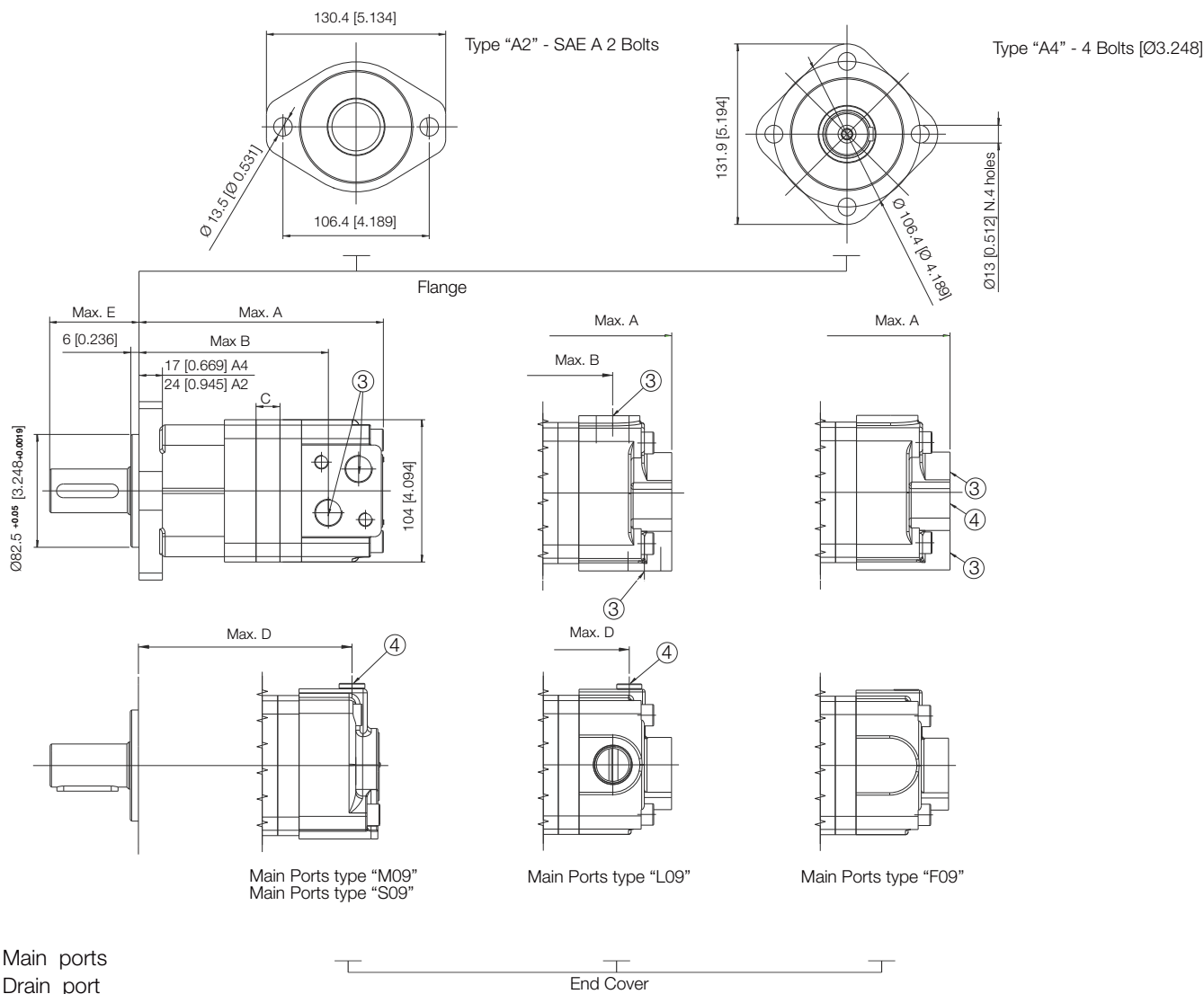

- ③ Main ports
- ④ Drain port

* For shafts dimensions see page



* For main ports dimensions see page



Main Ports type "S09"								
Displ. cm ³ /giro [in ³ /rev]	080 [4.8]	100 [6.1]	130 [7.9]	160 [9.7]	200 [12.2]	250 [15.2]	315 [19.2]	400 [24.4]
A mm [in]	174.5 [6.87]	177.5 [6.98]	182 [7.16]	188 [7.40]	195 [7.67]	203.5 [8.01]	215 [8.46]	228.5 [8.99]
B mm [in]	134 [5.27]	137.5 [5.41]	142 [5.59]	148 [5.82]	155 [6.10]	164 [6.45]	175 [6.88]	188.5 [7.42]
C mm [in]	14 [0.551]	17.4 [0.68]	21.8 [0.85]	27.8 [1.09]	34.8 [1.37]	43.5 [1.71]	54.8 [2.15]	68.4 [2.69]
D mm [in]	154 [6.06]	157 [6.18]	161 [6.33]	167.5 [6.59]	174.5 [6.87]	183.5 [7.22]	194.5 [7.65]	208 [8.18]
Weight kg [lb]	10.5 [23.1]	10.7 [23.6]	11 [24.5]	11.4 [25.1]	11.8 [26]	12.4 [27.3]	13.1 [28.8]	14 [30.8]

Main Ports type "L09" - Main Ports type "F09" - Main Ports type "R09"								
Displ. cm ³ /giro [in ³ /rev]	080 [4.8]	100 [6.1]	130 [7.9]	160 [9.7]	200 [12.2]	250 [15.2]	315 [19.2]	400 [24.4]
A mm [in]	185 [7.28]	188 [7.40]	192.5 [7.57]	198.5 [7.81]	205.5 [8.09]	214 [8.42]	225.5 [8.87]	239 [9.40]
B mm [in]	140 [5.51]	143.5 [5.64]	148 [5.82]	154 [6.06]	161 [6.33]	170 [6.69]	181 [7.12]	194.5 [7.65]
C mm [in]	14 [0.551]	17.4 [0.68]	21.8 [0.85]	27.8 [1.09]	34.8 [1.37]	43.5 [1.71]	54.8 [2.15]	68.4 [2.69]
D mm [in]	153 [6.02]	156 [6.14]	160 [6.29]	166.5 [6.55]	173.5 [6.83]	182.5 [7.18]	193.5 [7.61]	207 [8.14]
Weight kg [lb]	10.5 [23.1]	10.7 [23.6]	11 [24.5]	11.4 [25.1]	11.8 [26]	12.4 [27.3]	13.1 [28.8]	14 [30.8]

SHAFT	CL320	C3175	CL254	CN320	SE250	SE320	SC320	SE350
E mm [in]	65 [2.55]	56 [2.20]	51 [2.00]	65.9 [2.59]	51 [2.00]	55.9 [2.20]	65 [2.55]	110 [4.29]

Click **DANA** button to return to section index

Click **i** button to return to main index



- 1
- 2
- 3
- 4
- 5
- 6
- 7
- 8
- 9
- 10
- 11
- 12
- 13

HR W CM M09/S09/L09/F09

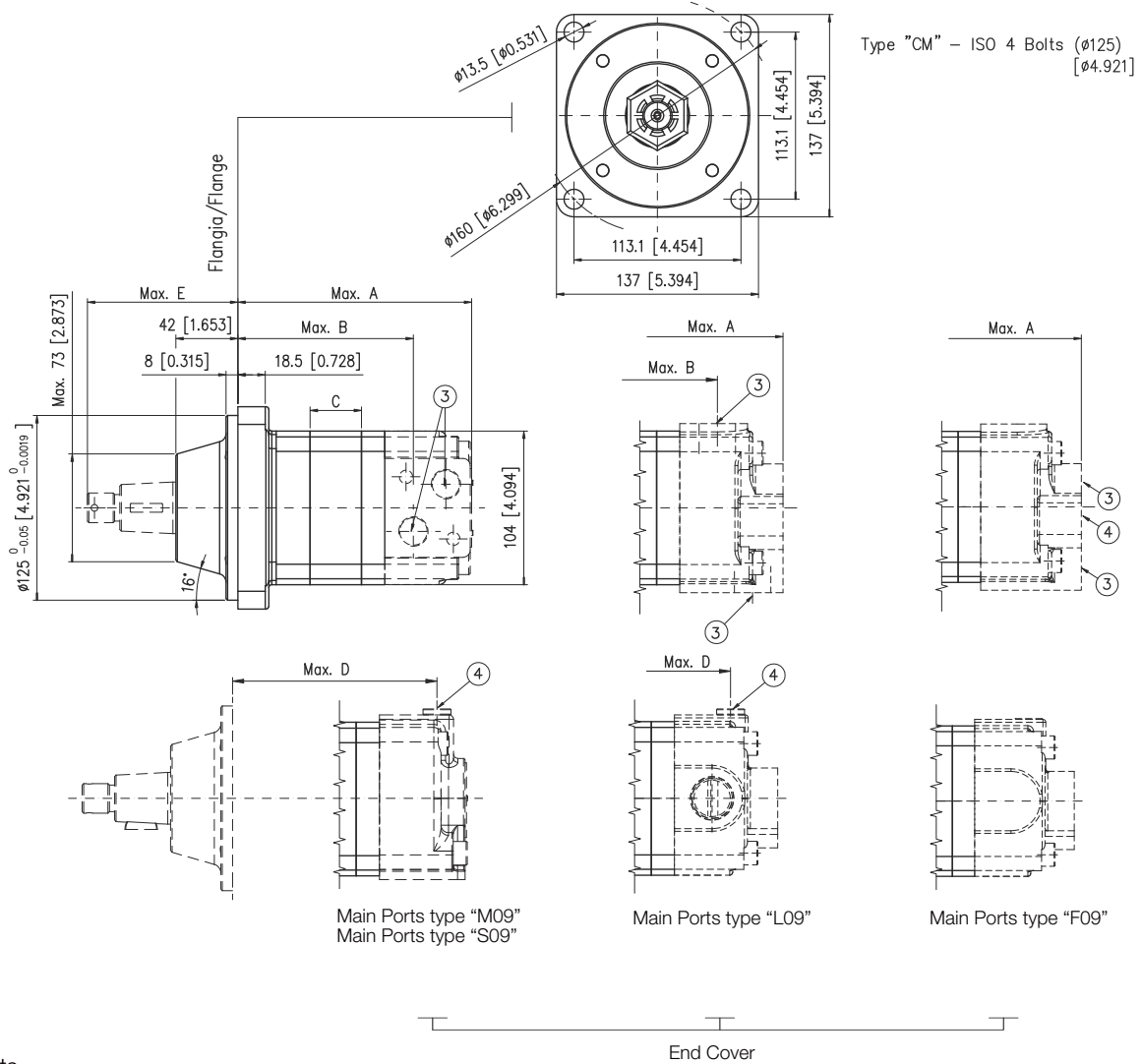

- ③ Main ports
- ④ Drain port

* For shafts dimensions see page



* For main ports dimensions see page



Main Ports type "M09" - Main Ports type "S09"								
Displ. cm ³ /giro [in ³ /rev]	080 [4.8]	100 [6.1]	130 [7.9]	160 [9.7]	200 [12.2]	250 [15.2]	315 [19.2]	400 [24.4]
A mm [in]	136.5 [5.37]	140 [5.51]	144.5 [5.68]	150.5 [5.92]	157.5 [6.20]	166 [6.53]	177.5 [6.98]	191 [7.51]
B mm [in]	97.5 [3.83]	101 [3.97]	105.3 [4.14]	111.3 [4.38]	118.3 [4.65]	127 [5.00]	138.5 [5.45]	152 [5.98]
C mm [in]	14 [0.551]	17.4 [0.68]	21.8 [0.85]	27.8 [1.09]	34.8 [1.37]	43.5 [1.71]	54.8 [2.15]	68.4 [2.69]
D mm [in]	117 [4.60]	120.5 [4.74]	124.8 [4.91]	130.8 [5.14]	137.8 [5.42]	146.5 [5.76]	158 [6.22]	171.5 [6.75]
Weight kg [lb]	10.9 [24]	11.1 [24.4]	11.5 [25.3]	11.8 [26]	12.2 [26.8]	12.9 [28.4]	13.6 [29.9]	14.4 [31.7]

Main Ports type "L09" - Main Ports type "F09" - Main Ports type "R09"								
Displ. cm ³ /giro [in ³ /rev]	080 [4.8]	100 [6.1]	130 [7.9]	160 [9.7]	200 [12.2]	250 [15.2]	315 [19.2]	400 [24.4]
A mm [in]	149.5 [5.88]	153 [6.02]	157.5 [6.20]	163.5 [6.43]	170.5 [6.71]	179 [7.04]	190.5 [7.50]	204 [8.03]
B mm [in]	103.5 [4.07]	107 [4.21]	111.3 [4.38]	117.3 [4.61]	124.3 [4.89]	133 [5.23]	144.5 [5.68]	158 [6.22]
C mm [in]	14 [0.551]	17.4 [0.68]	21.8 [0.85]	27.8 [1.09]	34.8 [1.37]	43.5 [1.71]	54.8 [2.15]	68.4 [2.69]
D mm [in]	114.5 [4.50]	118 [4.64]	122.3 [4.81]	128.3 [5.05]	135.5 [5.33]	144 [5.66]	155.5 [6.12]	169 [6.65]
Weight kg [lb]	10.9 [24]	11.1 [24.4]	11.5 [25.3]	11.8 [26]	12.2 [26.8]	12.9 [28.4]	13.6 [29.9]	14.4 [31.7]

SHAFT	CL320	CN320	SC320
E mm [in]	101 [3.97]	102 [4.01]	101 [3.97]

Click **i** button to return to main index

Click **DANA** button to return to section index



HR F A2/A4 M09/S09/L09/F09

Type "A2" – SAE A 2 Bolts

Type "A4" – 4 Bolts [ø3.248]

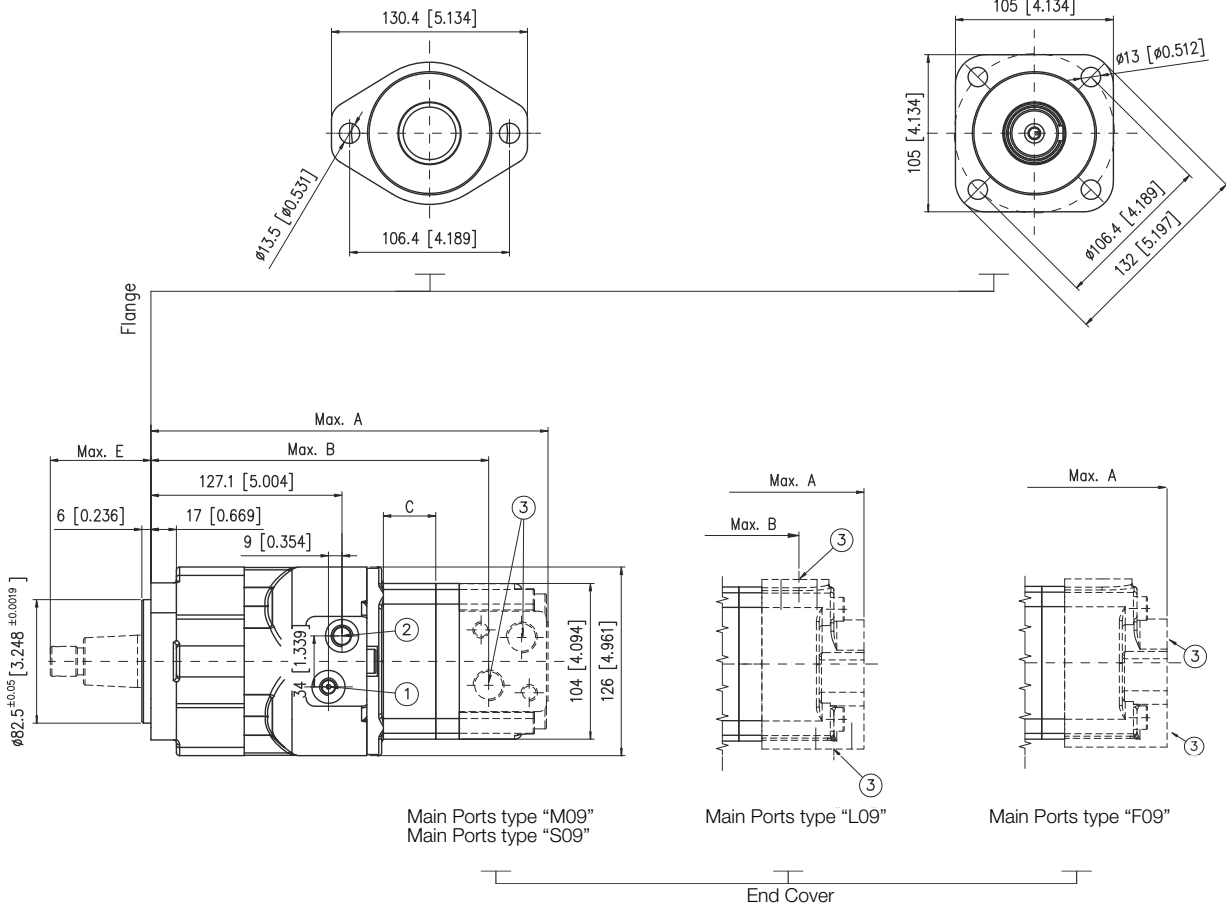

- ① 1/8 G (BSPP) Brake releasing plug, thread depth 11 mm [0.42 in] (ISO)
7/16" - 20 UNF Brake releasing plug, thread depth 11 mm [0.42 in] (SAE)
- ② 1/4 G (BSPP) Drain port, thread depth 11 mm [0.42 in] (ISO)
7/16" - 20 UNF Drain port, thread depth 11 mm [0.42 in] (SAE)
- ③ Main ports

* For shafts dimensions see page [F24](#)

* For main ports dimensions see page [F26](#)

* For brake feature see page [F18](#)

Main Ports type "M09" - Main Ports type "S09"								
Displ. cm ³ /giro [in ³ /rev]	080 [4.8]	100 [6.1]	130 [7.9]	160 [9.7]	200 [12.2]	250 [15.2]	315 [19.2]	400 [24.4]
A mm [in]	243.3 [9.57]	246.7 [9.71]	251.1 [9.88]	257.1 [10.12]	264.1 [10.39]	272.8 [10.74]	284.1 [11.18]	297.7 [11.72]
B mm [in]	203.8 [8.02]	207.2 [8.15]	211.6 [8.33]	217.6 [8.56]	224.6 [8.84]	233.3 [9.18]	244.6 [9.62]	258.2 [10.16]
C mm [in]	14 [0.551]	17.4 [0.68]	21.8 [0.85]	27.8 [1.09]	34.8 [1.37]	43.5 [1.71]	54.8 [2.15]	68.4 [2.69]
Weight kg [lb]	17.3 [38.1]	17.5 [38.5]	17.9 [39.4]	18.2 [40.1]	18.6 [40.9]	19.3 [42.5]	20 [44]	20.8 [45.8]

Main Ports type "L09" - Main Ports type "F09" - Main Ports type "R09"								
Displ. cm ³ /giro [in ³ /rev]	080 [4.8]	100 [6.1]	130 [7.9]	160 [9.7]	200 [12.2]	250 [15.2]	315 [19.2]	400 [24.4]
A mm [in]	254.3 [10.01]	257.7 [10.14]	262.1 [10.31]	268.1 [10.55]	275.1 [10.83]	283.8 [11.17]	295.1 [11.61]	308.7 [12.15]
B mm [in]	209.8 [8.25]	213.2 [8.39]	217.6 [8.56]	223.6 [8.80]	230.6 [9.07]	239.3 [9.42]	250.6 [9.86]	264.2 [10.40]
C mm [in]	14 [0.551]	17.4 [0.68]	21.8 [0.85]	27.8 [1.09]	34.8 [1.37]	43.5 [1.71]	54.8 [2.15]	68.4 [2.69]
Weight kg [lb]	17.3 [38.1]	17.5 [38.5]	17.9 [39.4]	18.2 [40.1]	18.6 [40.9]	19.3 [42.5]	20 [44]	20.8 [45.8]

SHAFT	CL320	CN320
E mm [in]	65 [2.55]	65.9 [2.59]

Click **DANA** button to return to section index

Click **i** button to return to main index



- 1
- 2
- 3
- 4
- 5
- 6
- 7
- 8
- 9
- 10
- 11
- 12
- 13

HR L CM M09/S09/L09/F09

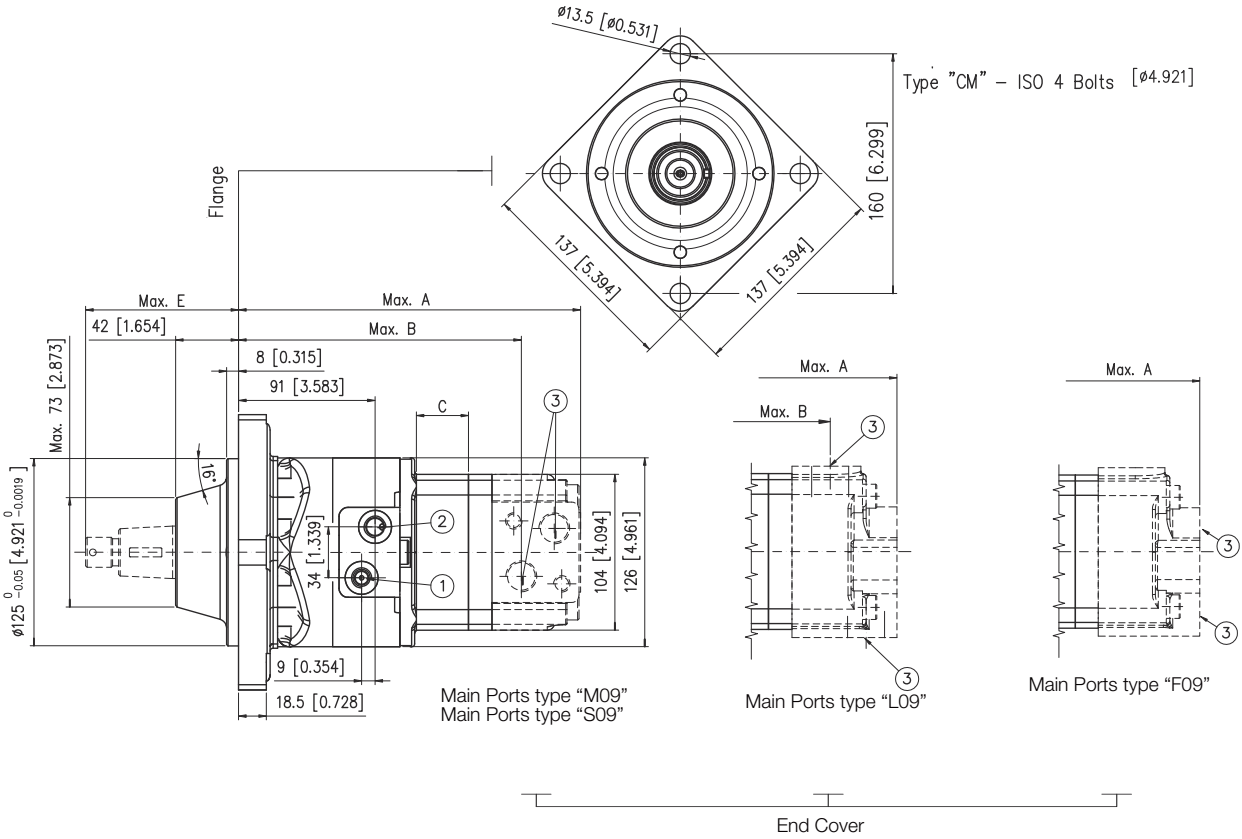

- ① 1/8 G (BSPP) Brake releasing plug, thread depth 11mm [0.42 in] (ISO)
7/16" - 20 UNF Brake releasing plug, thread depth 11mm [0.42 in] (SAE)
- ② 1/4 G (BSPP) Drain port, thread depth 11 mm [0.42 in] (ISO)
7/16" - 20 UNF Drain port, thread depth 11 mm [0.42 in] (SAE)
- ③ Main ports

* For shafts dimensions see page [F24](#)

* For main ports dimensions see page [F26](#)

* For brake feature see page [F18](#)

Main Ports type "M09" - Main Ports type "S09"								
Displ. cm ³ /giro [in ³ /rev]	080 [4.8]	100 [6.1]	130 [7.9]	160 [9.7]	200 [12.2]	250 [15.2]	315 [19.2]	400 [24.4]
A mm [in]	207.2 [8.15]	210.6 [8.29]	215 [8.46]	221 [8.70]	228 [8.97]	236.7 [9.31]	248 [9.76]	261.6 [10.29]
B mm [in]	167.7 [6.60]	171.1 [6.73]	175.5 [6.90]	181.5 [7.14]	188.5 [7.42]	197.2 [7.76]	208.5 [8.20]	222.1 [8.74]
C mm [in]	14 [0.551]	17.4 [0.68]	21.8 [0.85]	27.8 [1.09]	34.8 [1.37]	43.5 [1.71]	54.8 [2.15]	68.4 [2.69]
Weight kg [lb]	17.7 [39]	17.9 [39.4]	18.3 [40.3]	18.6 [40.9]	19 [41.8]	19.7 [43.4]	20.4 [44.9]	21.2 [46.7]

Main Ports type "L09" - Main Ports type "F09" - Main Ports type "R09"								
Displ. cm ³ /giro [in ³ /rev]	080 [4.8]	100 [6.1]	130 [7.9]	160 [9.7]	200 [12.2]	250 [15.2]	315 [19.2]	400 [24.4]
A mm [in]	218.2 [8.59]	221.6 [8.72]	226 [8.89]	232 [9.13]	239 [9.40]	247.7 [9.75]	259 [10.19]	272.6 [10.73]
B mm [in]	173.7 [6.83]	177.1 [6.97]	181.5 [7.14]	187.5 [7.38]	194.5 [7.65]	203.2 [8.00]	214.5 [8.44]	228.1 [8.98]
C mm [in]	14 [0.551]	17.4 [0.68]	21.8 [0.85]	27.8 [1.09]	34.8 [1.37]	43.5 [1.71]	54.8 [2.15]	68.4 [2.69]
Weight kg [lb]	17.7 [39]	17.9 [39.4]	18.3 [40.3]	18.6 [40.9]	19 [41.8]	19.7 [43.4]	20.4 [44.9]	21.2 [46.7]

SHAFT	CL320	CN320
E mm [in]	101 [3.97]	102 [4.01]

Click [i](#) button to return to main index

Click **DANA** button to return to section index



F Version - L Version

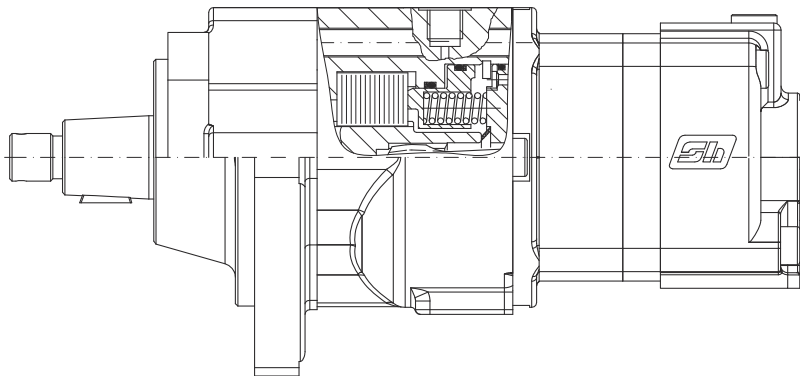

Starting release pressure	25 bar [362 psi]			
Full release pressure	30 bar [435 psi]			
Brake control pressure Max.	210 bar [3045 psi]			
STATIC BRAKING TORQUE				
MOTOR	STANDARD	12 Springs / 10 Contacts	8 Springs	Increased Braking Torque
F Version - L Version 080	210 Nm [154.7 lbf-ft]			
F Version - L Version 100	280 Nm [206.3 lbf-ft]	259 Nm [190.8 lbf-ft]		
F Version - L Version 130	340 Nm [250.5 lbf-ft]			
F Version - L Version 160	340 Nm [250.5 lbf-ft]			
F Version - L Version 200	420 Nm [309.5 lbf-ft]			560 Nm [412.7 lbf-ft]
F Version - L Version 250	470 Nm [346.3 lbf-ft]		313 Nm [230.6 lbf-ft]	560 Nm [412.7 lbf-ft]
F Version - L Version 315	560 Nm [412.7 lbf-ft]	259 Nm [190.8 lbf-ft]	373 Nm [274.9 lbf-ft]	
F Version - L Version 400	560 Nm [412.7 lbf-ft]		373 Nm [274.9 lbf-ft]	

The brakes built into F version and L version motors are multidisc pressure released ones for static operation. With no pressure from the pump to the motor, a set of springs will push the discs one against the other, hence the motor shaft will not be allowed to rotate unless the shaft itself is driven with a torque widely exceeding the max. static torque of the brake.

By sending pressure to the motor a shuttle valve (to be included in the system) will send pressure to the brake, overcome the resistance of the springs and release the brake hence allowing the start of the motor. Wheel motors require some care in the engineering of the machine. The major aspects to consider are:

- Hub and motor shaft tapers must be perfectly matching, in order to avoid excessive key stress, which can occur in case of bottoming of shaft tip washer and nut at the end of the thread.
- A proper service factor should be considered in case of shocks to the shaft (eg. With the machine travelling on very uneven soil).
- L version brake motors operating mobile machines should always have a flanged on double overcentre + shuttle valve, in order to ensure safe slow-down of the machine and engaging of brake when a complete stop has been reached.

OPEN LOOP SYSTEM, ONE BRAKE-MOTOR, BI-DIRECTIONAL TURNING AND AUTOMATIC BRAKE OPERATION.

This configuration is typically that of a slew drive (cranes, excavators, aerial platforms, derricks, etc.).
 When the pump delivers oil to the motor the consequent generation of pressure will operate the shuttle valve and activate the brake line, thus disengaging the brake itself. When the oil delivery is shut off to stop the machine, a double overcentre valve will slow down the rotative mass to an almost complete stop when the static brake will engage.

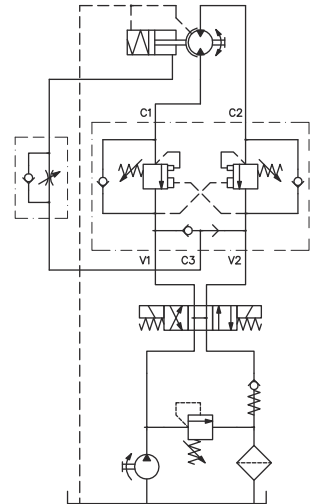

OPEN LOOP SYSTEM, TWO BRAKE-MOTORS, BI-DIRECTIONAL TURNING AND AUTOMATIC BRAKES OPERATION.

This is a typical layout of the travelling system of a mobile machine (aerial platforms, etc.).
 Fluid under pressure disengages the brakes and starts the two motors; a commutation device will connect the two motors either in series or parallel mode in order to have either speed or torque as main performance.
 The double overcentre valve will steadily slow down the machine and bring it to an almost complete stop when the brakes will engage.

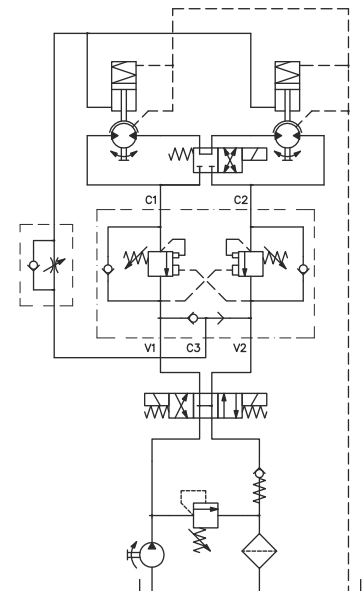

CLOSED LOOP SYSTEM, ONE BRAKEMOTOR, BI-DIRECTIONAL TURNING, AUTOMATIC BRAKE OPERATION AND VARIABLE PUMP.

A very typical system for sweepers. The pump delivers a variable flow of oil to the motor hence the machine can travel at variable speed.
 The brake is disengaged by the delivery of flow from the shuttle valve via the electro-valve (top, right) that will also release the fluid under pressure from inside the brake piston chamber when the motor stops and the brake engages.

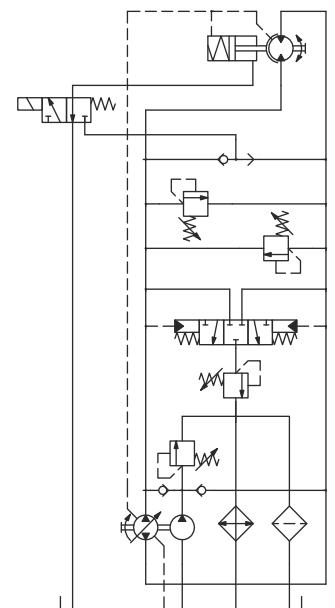

HR C B4 M09/S09/L09/F09

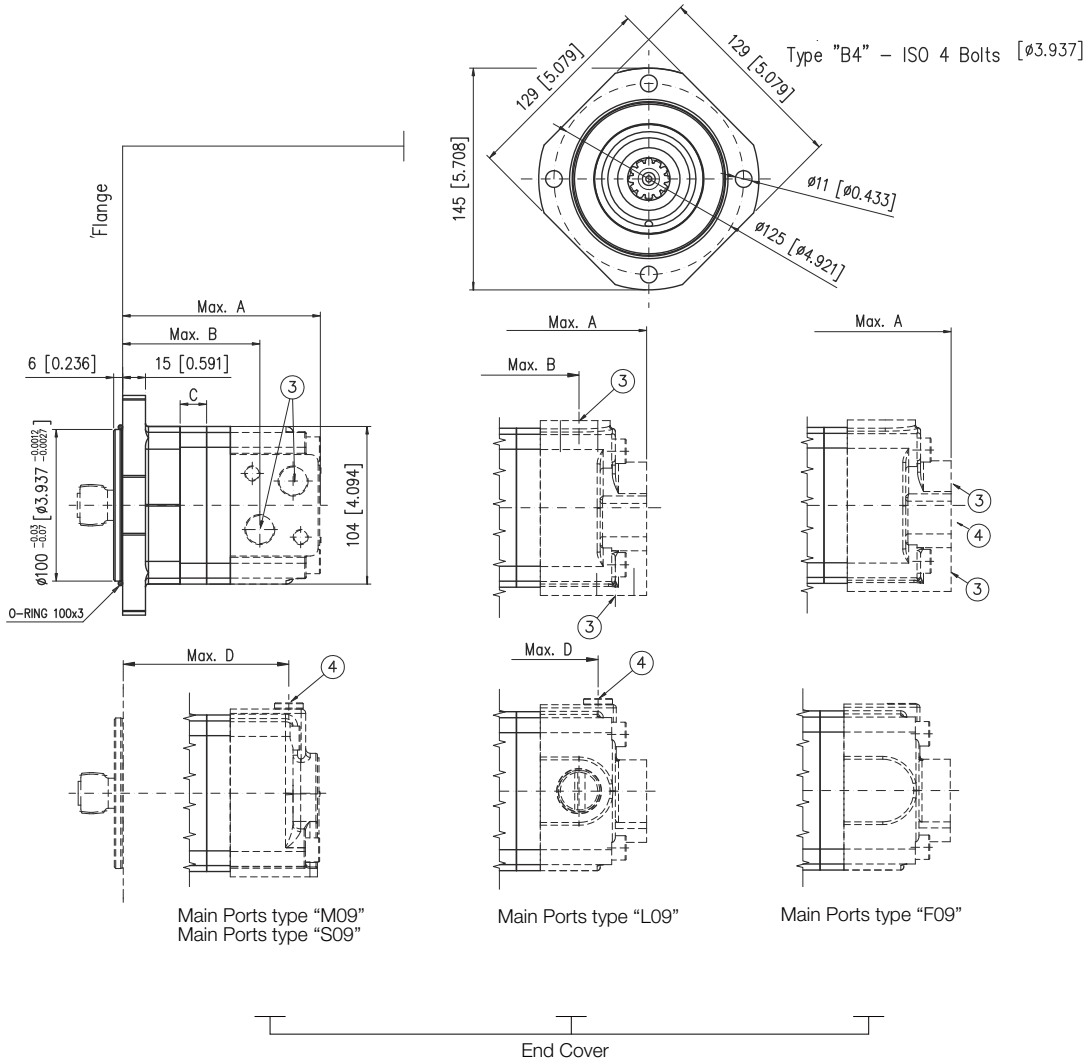

- ③ Main ports
- ④ Drain port

* For main ports dimensions see page [F26](#)

* For interface drawing see page [F21](#)

Main Ports type "M09"- Main Ports type "S09"								
Displ. cm ³ /giro [in ³ /rev]	080 [4.8]	100 [6.1]	130 [7.9]	160 [9.7]	200 [12.2]	250 [15.2]	315 [19.2]	400 [24.4]
A mm [in]	127.7 [5.02]	131 [5.15]	135.5 [5.33]	141.5 [5.57]	148.5 [5.84]	157.2 [6.18]	168.5 [6.63]	182 [7.16]
B mm [in]	87.2 [3.43]	90.6 [3.56]	95 [3.74]	101 [3.97]	108 [4.25]	116.7 [4.59]	128 [5.03]	141.6 [5.57]
C mm [in]	14 [0.551]	17.4 [0.68]	21.8 [0.85]	27.8 [1.09]	34.8 [1.37]	43.5 [1.71]	54.8 [2.15]	68.4 [2.69]
D mm [in]	106.7 [4.20]	110 [4.33]	114.5 [4.50]	120.5 [4.74]	127.5 [5.01]	136.2 [5.36]	147.5 [5.80]	161 [6.33]
Weight kg [lb]	8 [17.6]	8.2 [18]	8.6 [18.9]	8.9 [19.6]	9.3 [20.4]	10 [22]	10.7 [23.5]	11.5 [25.3]

Main Ports type "L09" - Main Ports type "F09" - Main Ports type "R09"								
Displ. cm ³ /giro [in ³ /rev]	080 [4.8]	100 [6.1]	130 [7.9]	160 [9.7]	200 [12.2]	250 [15.2]	315 [19.2]	400 [24.4]
A mm [in]	140.7 [5.53]	144 [5.66]	149.5 [5.88]	154.5 [6.08]	161.5 [6.35]	170.2 [6.70]	181.5 [7.14]	195 [7.67]
B mm [in]	93.2 [3.66]	96.6 [3.80]	101 [3.97]	107 [4.21]	114 [4.48]	122.7 [4.83]	134 [5.27]	147.6 [5.81]
C mm [in]	14 [0.551]	17.4 [0.68]	21.8 [0.85]	27.8 [1.09]	34.8 [1.37]	43.5 [1.71]	54.8 [2.15]	68.4 [2.69]
D mm [in]	104.2 [4.10]	107.5 [4.23]	112 [4.40]	118 [4.64]	125 [4.92]	133.7 [5.26]	145 [5.70]	158.5 [6.24]
Weight kg [lb]	8 [17.6]	8.2 [18]	8.6 [18.9]	8.9 [19.6]	9.3 [20.4]	10 [22]	10.7 [23.5]	11.5 [25.3]

Click **DANA** button to return to section index

Click **i** button to return to main index



INTERFACE DRAWING FOR HR MOTOR “C” VERSION

Spline ANS B 92.1 + 1970 Class 5 (corrected $m \cdot x=0.8$)	
Diametral pitch	12/24
Number of teeth	Z=12
Pitch diameter	Dp=25.4
Pressure angle	30°
Module	m=2.1166
Minor diameter	Di=23.0 ^{+0.033} 0
Major diameter	De=28.0 -0.1
Max measurement between pins*	17.62 ^{+0.15} 0
Pins diameter	4.835 ±0.001
* Finished dimensions (when hardened)	

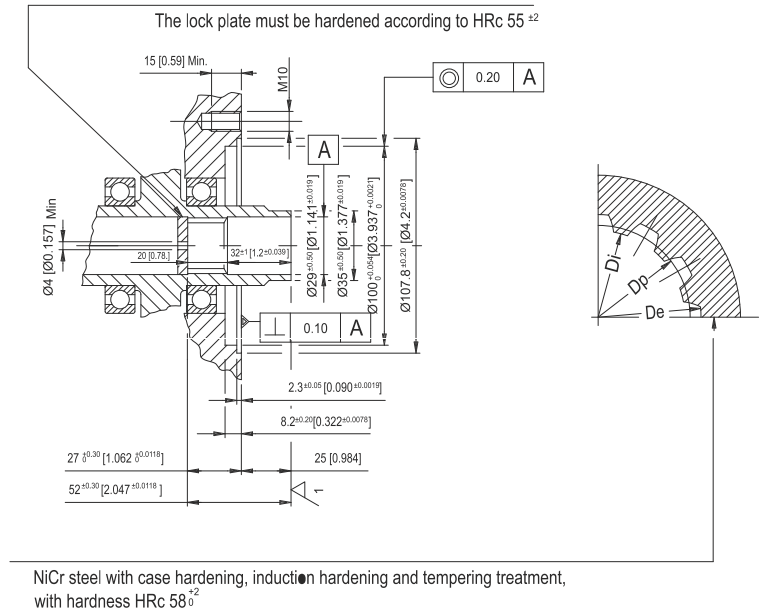

HR M M4 M09

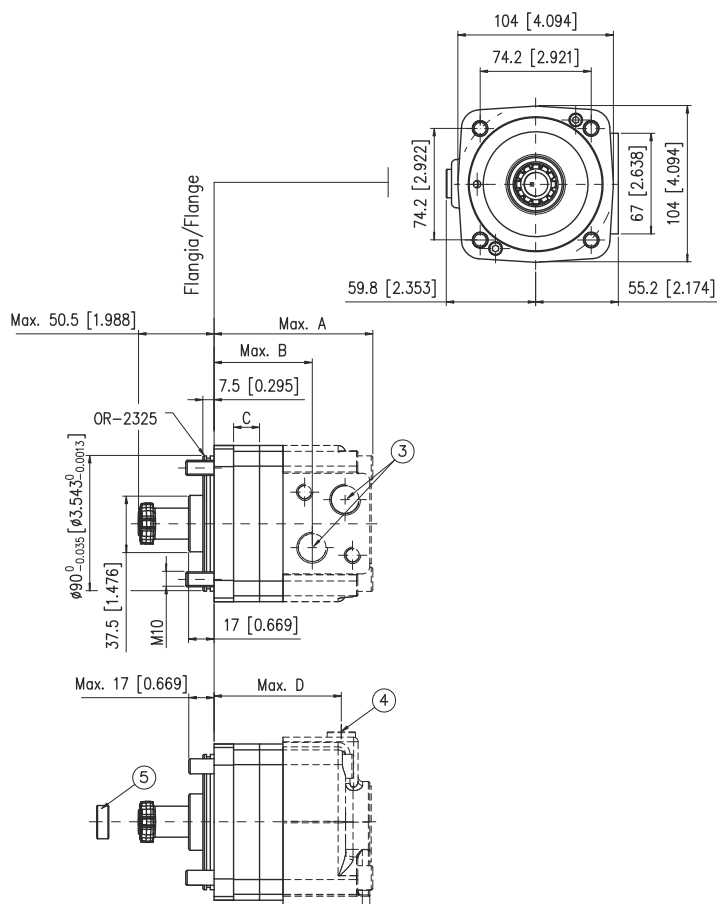

Main Ports type "M09"

End Cover

- ③ Main ports
- ④ Drain port
- ⑤ The motors are supplied with spacer

* For interface drawing see page



Main Ports type "M09"								
Displ. (cm ³ /giro) [in ³ /rev]	080 [4.8]	100 [6.1]	130 [7.9]	160 [9.7]	200 [12.2]	250 [15.2]	315 [19.2]	400 [24.4]
A mm [in]	102.6 [4.03]	106 [4.17]	110.4 [4.34]	116.4 [4.58]	123.4 [4.85]	132.1 [5.20]	143.4 [5.64]	157 [6.18]
B mm [in]	62.2 [2.44]	65.6 [2.58]	70 [2.75]	76 [2.99]	83 [3.26]	91.7 [3.61]	103 [4.05]	116.6 [4.59]
C mm [in]	14 [0.551]	17.4 [0.68]	21.8 [0.85]	27.8 [1.09]	34.8 [1.37]	43.5 [1.71]	54.8 [2.15]	68.4 [2.69]
D mm [in]	81.6 [3.21]	85 [3.34]	89.4 [3.51]	95.4 [3.75]	102.4 [4.03]	111.1 [4.37]	122.4 [4.81]	136 [5.35]
Weight kg [lb]	6.5 [14.3]	6.7 [14.7]	7.1 [15.6]	7.5 [16.5]	8 [17.6]	8.6 [18.9]	9.4 [20.7]	10.3 [22.7]

Click **DANA** button to return to section index

Click **i** button to return to main index

INTERFACE DRAWING FOR HR MOTOR “M” VERSION

Spline ANS B 92.1 + 1970 Class 5 (corrected $m \cdot x = 0.8$)	
Diametral pitch	12/24
Number of teeth	Z=12
Pitch diameter	Dp=25.4
Pressure angle	30°
Module	m=2.1166
Minor diameter	Di=23.0 $\begin{matrix} +0.033 \\ 0 \end{matrix}$
Major diameter	De=28.0 $\begin{matrix} 0 \\ -0.1 \end{matrix}$
Max measurement between pins*	17.62 $\begin{matrix} +0.15 \\ 0.1 \end{matrix}$
Pins diameter	4.835 $\begin{matrix} +0.001 \\ -0.001 \end{matrix}$
* Finished dimensions (when hardened)	

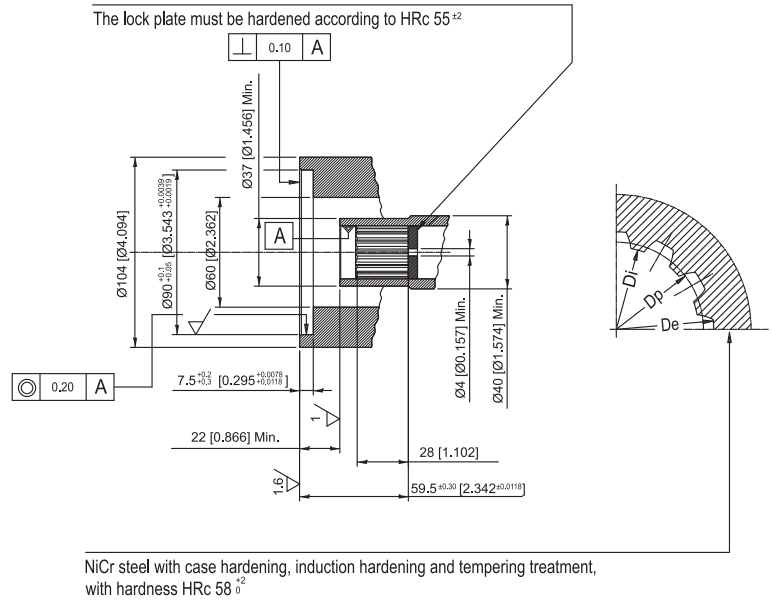

- 1
- 2
- 3
- 4
- 5
- 6
- 7
- 8
- 9
- 10
- 11
- 12
- 13

CL254 Cylindrical Shaft

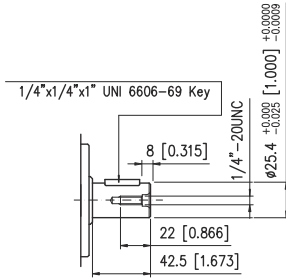

Max. admissible Torque
(Cont. 300 Nm [221 lbf-ft] - Int. 410 Nm [302 lbf-ft])

CL025 Cylindrical Shaft

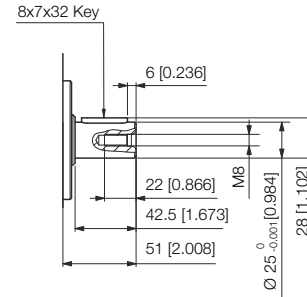

Max. admissible Torque
(Cont. 300 Nm [221 lbf-ft] - Int. 410 Nm [302 lbf-ft])

SE250 Splined Shaft

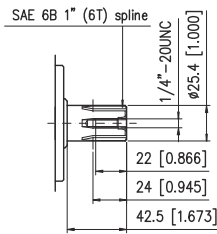

Max. admissible Torque
(Cont. 360 Nm [265 lbf-ft] - Int. 450 Nm [332 lbf-ft])

C3175 Cylindrical Shaft

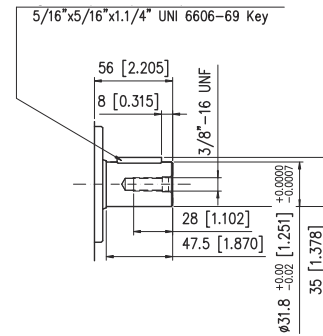

Max. admissible Torque
(Cont. 768 Nm [566 lbf-ft])

SC320 Splined Shaft

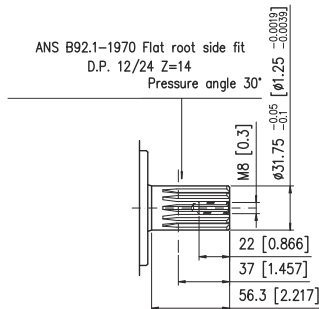

Max. admissible Torque
(Cont. 768 Nm [566 lbf-ft])

CL320 Cylindrical Shaft

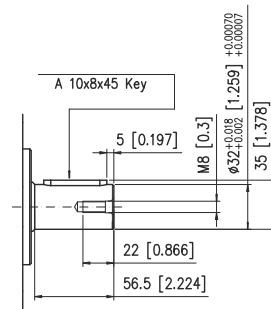

Max. admissible Torque
(Cont. 768 Nm [566 lbf-ft])

Click **DANA** button to return to section index

Click **i** button to return to main index

1

2

3

4

5

6

7

8

9

10

11

12

13

SE320 Splined Shaft

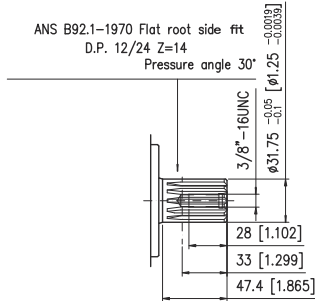

Max. admissible Torque
(Cont. 768 Nm [566 lbf-ft])

CN320 Tapered Shaft

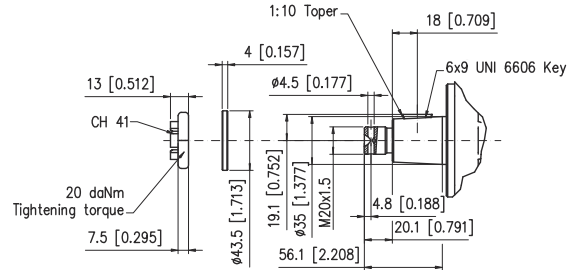

Max. admissible Torque
(Cont. 860 Nm [633.82 lbf-ft])

SE350 Splined Shaft

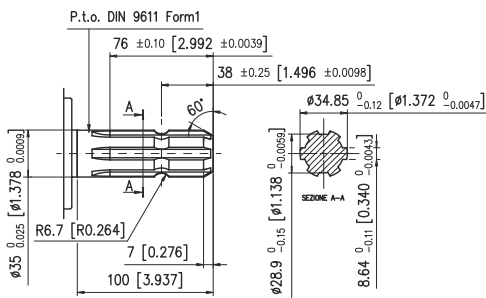

Max. admissible Torque
(Cont. 860 Nm [633.82 lbf-ft])

Main ports dimensions and direction of rotation

1	2	3	4	5	6	7	8	9	10	11	12	13
---	---	---	---	---	---	---	---	---	----	----	----	----

M09 1/2 G BSPP (32x22)

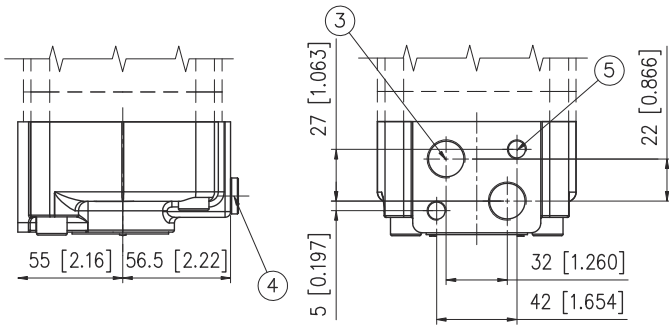

- ③ N° 2 Bolts 1/2 G (BSPP) main ports thread depth 15 mm [0.59 in]
- ④ 1/4 G (BSPP) drain port thread depth 13 mm [0.511 in]
- ⑤ N° 2 M10 thread depth 15 mm [0.59 in]

S Version

C Version

W Version

F Version

L Version

M Version

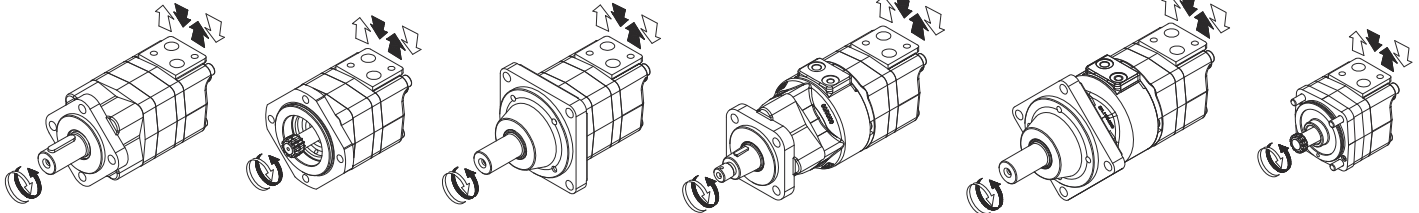

S09 7/8" - 14 UNF (32x22)

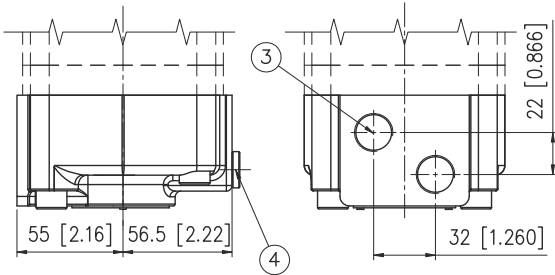

- ③ N° 2 Bolts 7/8" - 14 UNF main ports thread depth 17 mm [0.66 in]
- ④ 7/16" - 20 UNF drain port thread depth 13 mm [0.511 in]

S Version

C Version

W Version

F Version

L Version

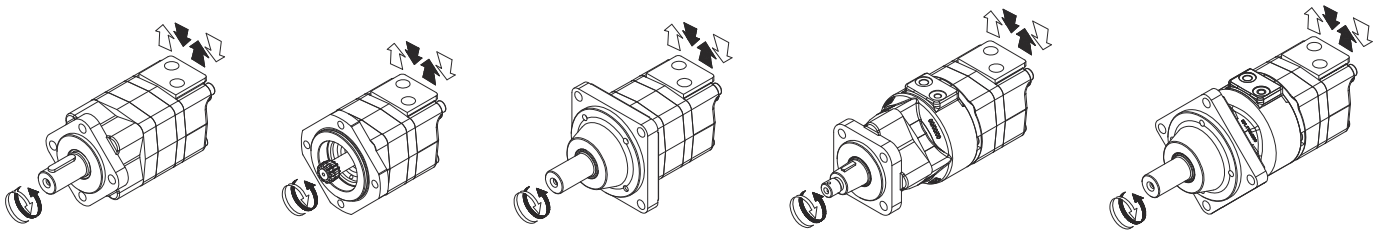

Click **DANA** button to return to section index

Click **i** button to return to main index

Main ports dimensions and direction of rotation

1	2	3	4	5	6	7	8	9	10	11	12	13
---	---	---	---	---	---	---	---	---	----	----	----	----

L09 1" 1/16 - 12 UN (Main Ports Positioned 180° apart)

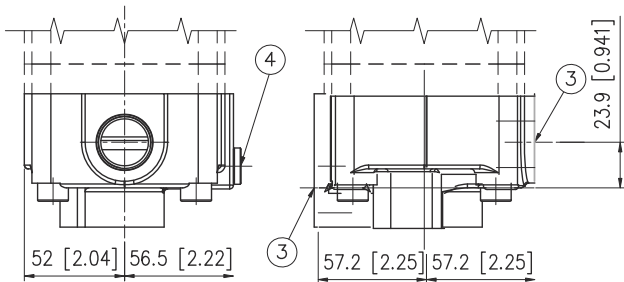

- ③ N° 2 Bolts 1" 1/16 - 12 UN main ports thread depth 20 mm [0.78 in]
- ④ 7/16" - 20 UNF drain port thread depth 13 mm [0.511 in]

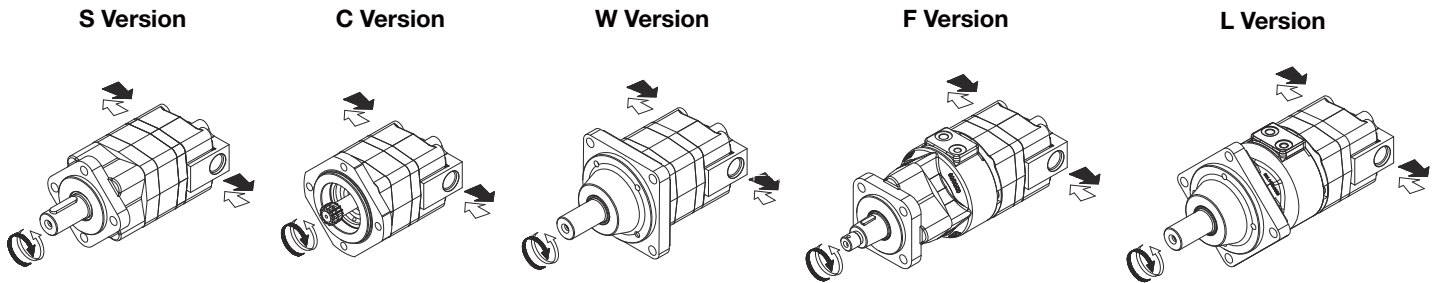

S09 1" 1/16 - 12 UN (End Main Ports)

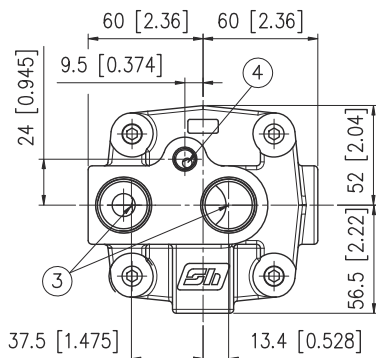

- ③ N° 2 Bolts 1" 1/16 - 12 UN main ports thread depth 17 mm [0.66 in]
- ④ 7/16" - 20 UNF drain port thread depth 13 mm [0.511 in]

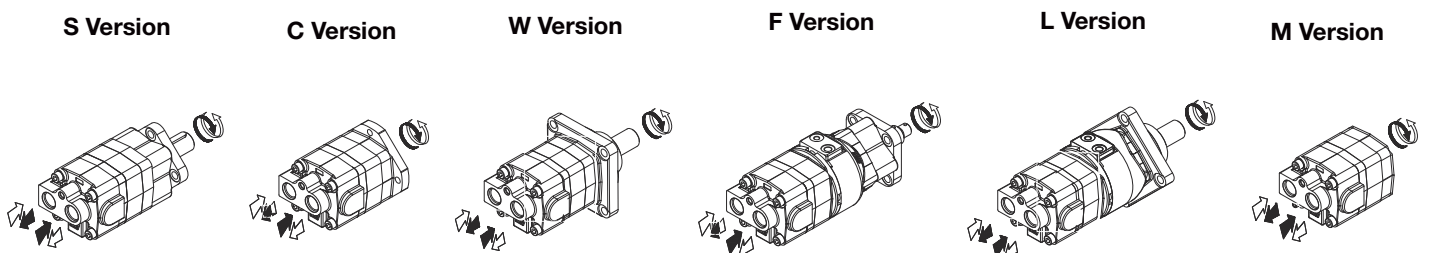

Click **i** button to return to main index

Click **DANA** button to return to section index



SECONDARY DRAIN PORT (AT DELIVERY SIDE)

For the motor with S-W version, it is possible to put a secondary drain port (at delivery side).

If it is necessary on the motor a secondary drain port, to specify in the purchase order the value "OKK" for metric version or "SKK" for SAE version (See position 12 of ordering code)

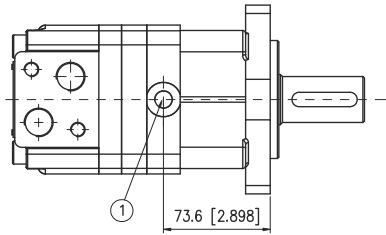

S Version

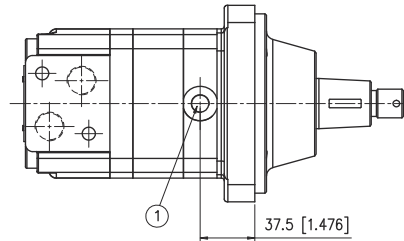

W Version

- ① 1/4 G (BSPP) drain port (OK)
- 7/16" - 20 UNF drain port (SK)

LOW LEAKAGE

For applications with low flow and high working pressure, it is recommended the Low Leakage version. The Low Leakage version differs from the standard version for the different internal components.

SPECIAL COVER FOR FLUSHING VALVE

To mount the flushing valve on motors, it is necessary to use a special cover. This is only possible with the "M09 - S09" main ports. If it is necessary to assemble the flushing valve on motors, to specify in the purchase order the valves type 06-09-15-21 (See position 10 of ordering code)

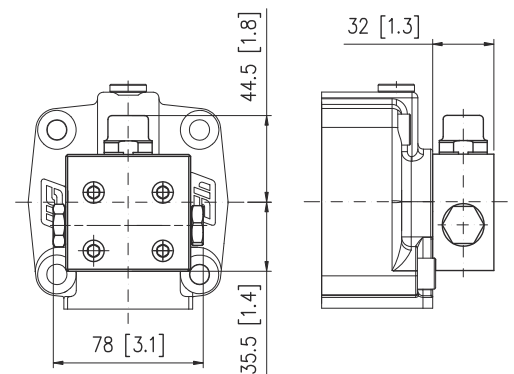

For more informations on the Flushing valve, see the Valves and Accessories section or Service Bulletin - 05-0082-A04

Click **DANA** button to return to section index

Click **i** button to return to main index



1

2

3

4

5

6

7

8

9

10

11

12

13

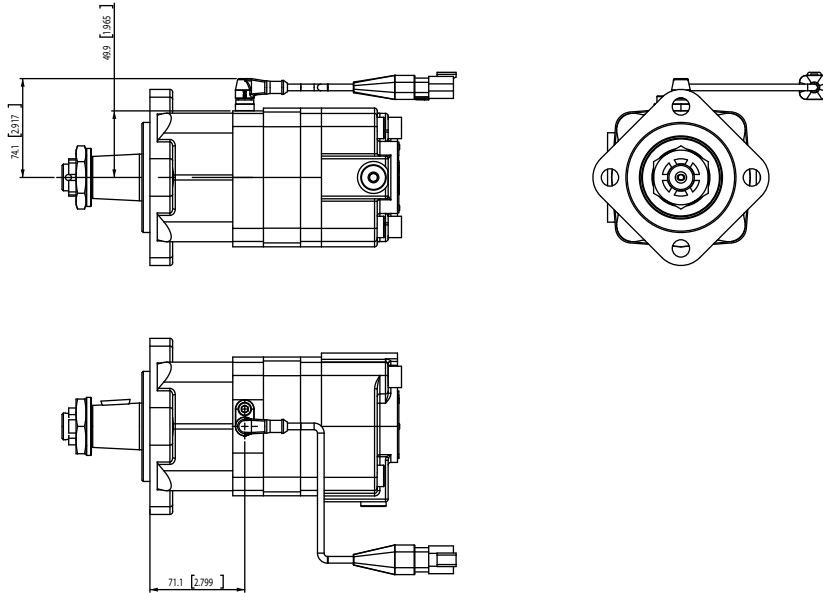
TZ Tachometer + sensor 2-channel-Hall effect (55 pulse)**Main features:**

2-channel differential-hall effect operating principle sensor

Output: dual-channel (90°)

Power supply: 8-32 VDC

Frequency : 0-20000 Hz

Operating temperature: -40°C / +125°C

Number of pulses per revolution: 55



BREVINI[®]

Motion Systems

